

★ CERTIFICAT DE CONFORMITE ★

CONFORMITY CERTIFICATE ~ CERTIFICADO DE CONFORMIDAD ~ INSTEMMING VERKLARING ~ KONFORMITÄTS BESCHEINIGUNG
KONFORMITETS BEVIS ~ CERTIFICATO DE CONFORMIDADE ~ ATITIKTIES DEKLARACIJA ~ CERTYFIKAT ZGODNOŚCI ~ СЕРТИФИКАТ
СООТВЕТСТВИЯ ~ CERTIFICAT DE CONFORMITATE ~ СЕРТИФИКАТ ЗА СЪОТВЕТСТВИЕ.

UNI-CORP EUROPE / PACLITE-EQUIPMENT



33 Avenue Pierre Brossolette
94000 Creteil France.

☎ +33 (0) 1 49 81 69 55 ☎ +33 (0) 1 48 98 40 88

🌐 www.paclite-equip.com

certifie que la machine spécifiée

hereby certify that the equipment specified bellow ~ certifica que la máquina especificada ~ Bescheinigt, dass da Gerät angegebenen
bescheinigt, daß das Baugerät bekræfter, at følgende maskine ~ certifica que o equipamento especificação ~ šiuo sertifikatu patvirtina,
kad žemiau nurodytas prietaisas, t.y. Zaświadcza, że wyszczególniona maszyna ~ Подтверждает, что нижеописанная машина
Certifica si declara ca echipamentul mentionat mai jos ~ Потвърждаваме, че оборудването, описано по-долу.

MULTIVIB, MULTIVIB COMPACT, FUZ, VX PREMIUM , VX BOOSTER, SYNCHROMASTER,

Est produit conforme aux dispositions des directives,

has been manufactured according to the following standards ~ es de conformidad con todas las disposiciones y directivas ~
in übereinstimmung mit folgenden richtlinien hergestellt ~ é fabricado conforme as seguintes normas ~ buvo pagamintas
laikantis toliau išvardintų standartų została wyprodukowana zgodnie z następującymi normami ~ Произведена в
соответствии со следующими нормами este fabricat cu respectarea urmatoarelor standarde ~ е произведено в
съответствие със следните стандарти

**2006/42/CE, 2006/95/CE, 2004/108/CE, 2000/14/CE,
2002/44/CE, 2002/95/CE, 2002/96/CE**

Total Quality assurance system: CERTIFICATION MANAGEMENT SYSTEM



Standard: ISO 9001: 2008

Certificate N°: 0.04.11180

Issued on 14th December 2009

Valid until 04th October 2012

Technical manager



TYPES / MODELS

VX PREMIUM

42V 200Hz

- (E) Manual del Operador
- (GB) Operators Manual
- (F) Manuel De L'Opérateur
- (S) Bruksanvisning
- (PL) Instrukcja Obsługi
- (RUS) Руководство для оператора
- (LT) Naudojimo Instrukcija
- (RO) Manual de Utilizare
- (NO) Betjenes Håndbok
- (CZ) Na'vod K Obzluze
- (D) Bedienungshandbuch
- (BG) Оператор Ръчен



VXPREM12/01



* SEGURIDAD ELECTRICA * ELECTRICAL SAFETY * SECURITE ELECTRIQUE *
 ELEKTRISK SAKERHET * BEZPIECZENSTWO ELEKTRYCZNE *
 ЭЛЕКТРИЧЕСКАЯ БЕЗОПАСНОСТЬ * DARBO SU ELEKTRINIAIS *
 SIGURANTA ELECTRIC * ELEKTRISK SIKKERHET * ELEKTRICKYM NARADIM
 * ELEKTRISCHE SICHERHEIT * ЕЛЕКТРИЧЕСКА БЕЗОПАСНОСТ *

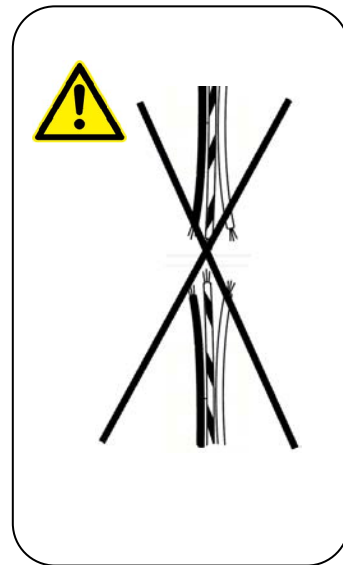
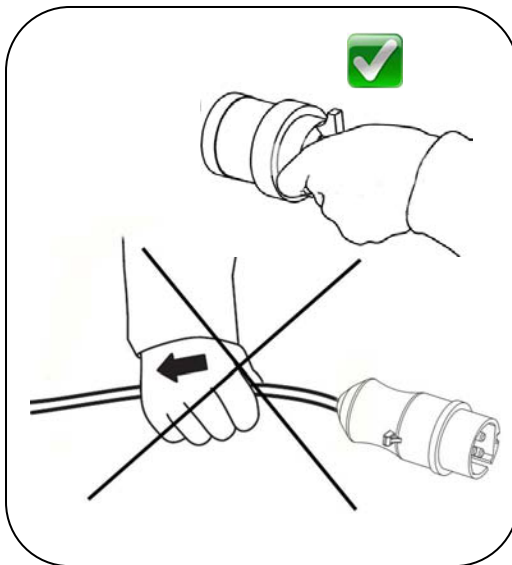
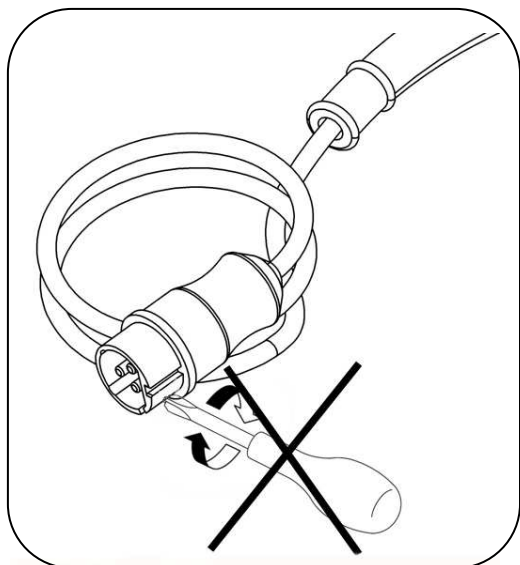

- *Precaución: Red con toma tierra
- *Warning: Grounding electrical network
- *Attention: Réseau électrique à la terre
- *Varning: Elnätet elektrisk jordning
- *Uwaga: Sieć elektryczna uziemienia
- *Внимание: сети электрического заземления
- *Atsargiai: Maitinimo elektros įžeminimo
- *Atenție: Rețea de împământare electrică
- *Advarsel: Stikkontakt grunnstøting
- *Upozornění: Napájecí elektrické uzemnění
- *Achtung: Netz elektrischen Erdung
- *Внимание: електрическата мрежа електрически заземяване

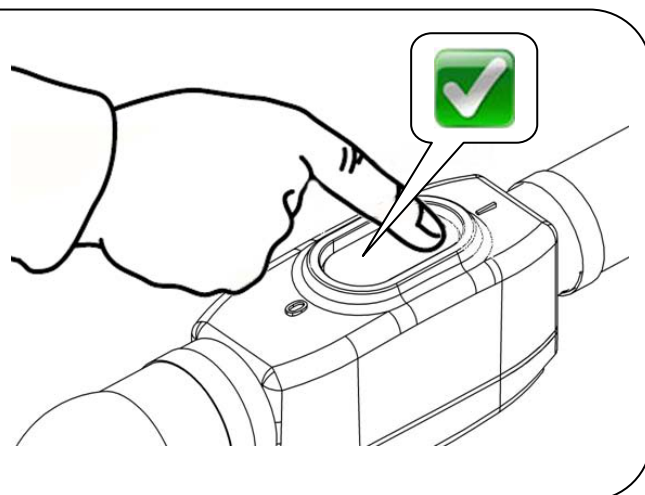
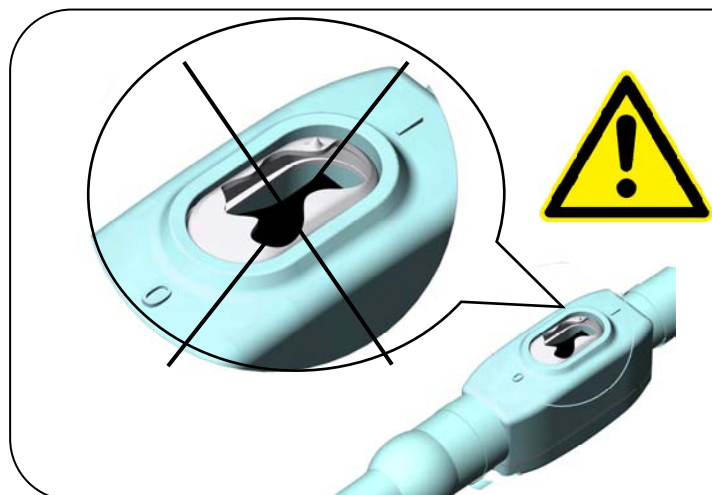

* MEDIO AMBIENTE * ENVIRONMENT * ENVIRONNEMENT * MILJÖ *
ŚRODOWISKO * ОКРУЖАЮЩЕЙ СРЕДЫ * APLINKA * MEDIU * MILJØ * ZIVOTNI
PROSTREDI * UMWELTSCHUTZ * ОКОЛНАТА СРЕДА *

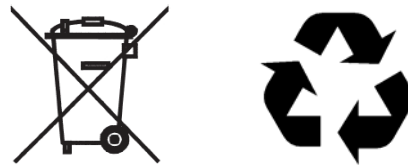

* SEGURIDAD GENERAL * GENERAL SAFETY * GENERALE DE SECURITE *
* ALLMÄN SÄKERHET * BEZPIECZEŃSTWA * ОБЩАЯ БЕЗОПАСНОСТЬ
* BENDROSIOS SAUGOS * SIGURANTA * GENERELL SIKKERHET * OBECNE
BEZPECNOSTNI POKYNY * ALLGEMEINE SICHERHEIT * ОБЩИ БЕЗОПАСНОСТ *



* AREA DE TRABAJO * WORK AREA * ZONE DE TRAVAIL *
ARBETSOMRADE * OBSZAR ROBOCZY * РАБОЧЕЕ МЕСТО * DARBO
VIETA * ZONA DE LUCRU * ARBEIDSOMRADE * PRACOVISTE *
ARBEITSUMFELD * РАБОТНОТО МЯСТО *



* QUICK VIEW * 



FUZ Converters

PACLITE VX PREMIUM

Equipment

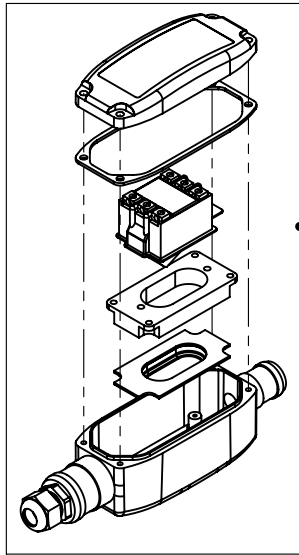

- 30.327.1 (NO SWITCH) VX40
- 30.328.1 (SWITCH) VX40
- 30.331.1 (NO SWITCH) VX45
- 30.332.1 (SWITCH) VX45

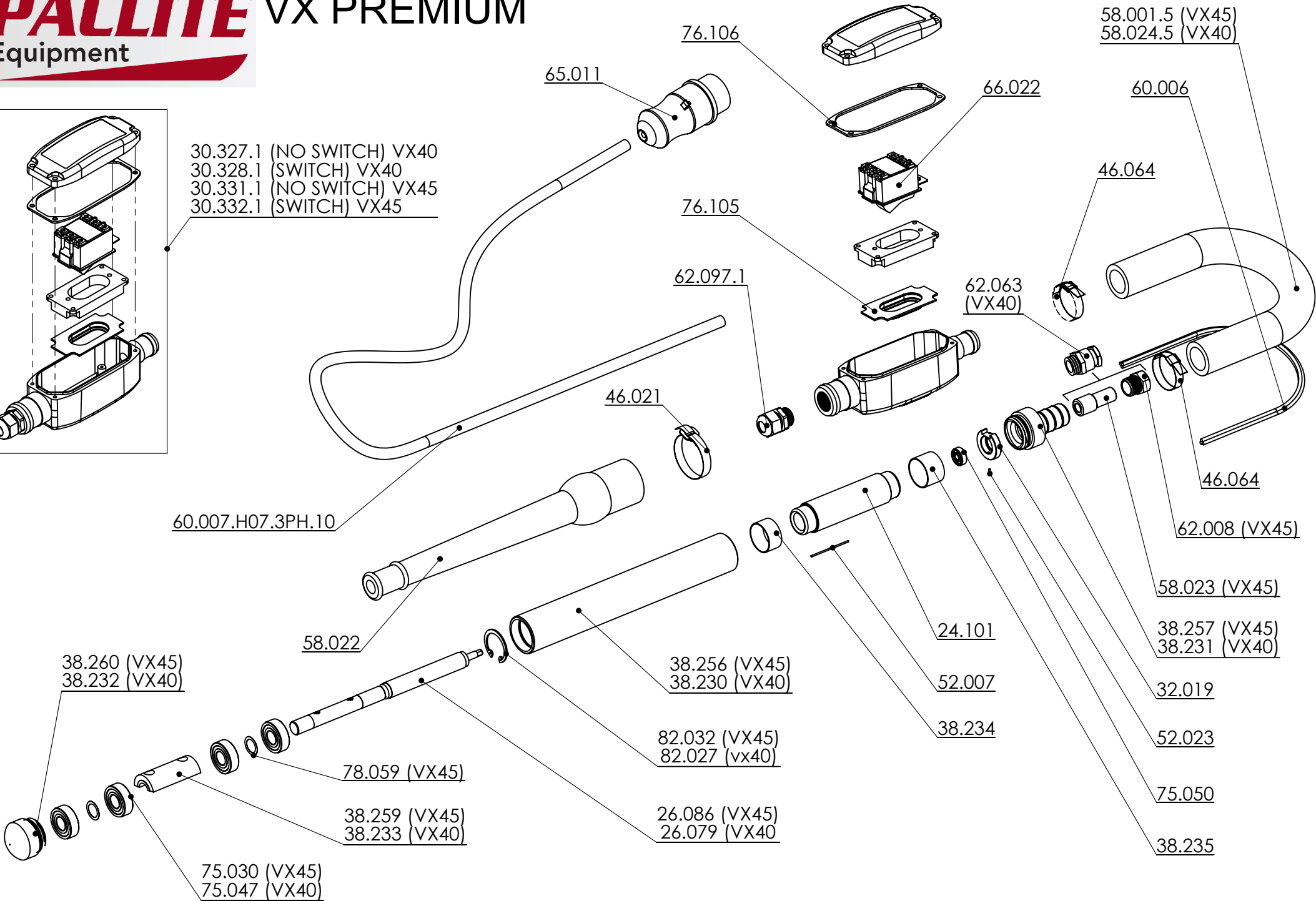

* ALMACENAJE Y TRANSPORTE * STORAGE & TRANSPORTATION * STOKAGE & TRANSPORT * FÖRVARING & TRANSPORT * PRZECHOWYWANIE & TRANSPORT
 * ТРАНСПОРТ * LAIKYMAS & TRANSPORTAVIMAS * DEPOZITAREA & TRANSPORTAREA * LAGRING OG TRANSPORT * SKLADOVANI A PREPRAVA * LANGERUNG & TRANSPORT * СЪХРАНЕНИЕ И ТРАНСПОРТ *

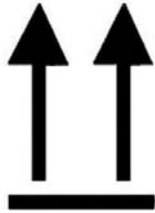

* GARANTIA * WARRANTY * GARANTIE * GARANTI * GWARANCJA * ГАРАНТИЯ
 * GARANTIJA * GARANTIA * GARANTI * ZARUKA * GARANTIE * ГАРАНЦІЯ *



WARRANTY



CONDICIONES DE GARANTIA CONSULTE CON SU DISTRIBUIDOR.
 WARRANTY TERMS CHECK WITH YOUR LOCAL DEALER.

TERMES DE LA GARANTIE VÉRIFIEZ AVEC VOTRE REVENDEUR LOCAL.

GARANTIVILLKOREN KONTROLLERA MED DIN LOKALA ATERFÖRSÄLJARE.

WARUNKI GWARANCJI INNYCH KRAJÓW SPRAWDŹ Z LOKALNYM SPRZEDAWCA.

УСЛОВИЯ ГАРАНТИИ ДРУГИЕ СТРАНЫ Проверьте с вашим местным дилером.

GARANTIJOS SĄLYGOS KITŲ ŠALIŲ PATIKRINTI SU SAVO VIETOS ATSTOVAS.

TERMENI DE GARANȚIE Consultați-vă CU DISTRIBUITORUL LOCAL.

GARANTIBETINGELSENE SJEKK MED DIN LOKALE FORHANDLER.

ZÁRUČNÍ PODMÍNKY DALŠÍ ZEMĚ Poradte se s místními prodejci.

GARANTIEBEDINGUNGEN PRÜFEN VON IHREM HÄNDLER.

Гарантионни условия ДРУГИ ДЪРЖАВИ Консултирайте се с вашия местен дилър.

WARRANTY COVERAGES



Mano de obra y piezas por defecto de fabricación

Labor and parts for manufacturing defects

Travail et de pièces pour des défauts de fabrication

Arbete och delar för tillverkningsfel

Pracy i części do wad fabrycznych

Труда и детали для производственных дефектов

Darbo ir dalys gamybos defektų

Forței de muncă și piese pentru defecte de fabricație

Arbeid og deler for produksjonsfeil

Práce a dílů pro výrobní vady

Arbeitszeit und Teile für Fabrikationsfehler

Труда и части за фабрични дефекти

* SERVICIO Y MANTENIMIENTO * SERVICE AND MAINTENANCE * ENTRETIEN ET REVISION * SERVICE & UNDERHALL * SERWIS I KONSERWACJA * СЕРВИС И ОБСЛУЖИВАНИЕ * TECHNINE PRIEZIURA * SERVICE SI INTRETINERE * SERVICE OG VEDLIKEHOLD * SERVIS A UDRZBA * SERVICE AND WARTUNG * ОБСЛУЖВАНЕ И ПОДДЪРЖАНЕ *



grasa sintetica*synthetic grease*graisse synthétique*Syntetiskt fett*smaru syntetycznego*синтетическая смазка*sintetinis tepalas*sintetic unsoare*syntetiske fett*syntetický mazací tuk*synthetisches Fett*синтетични мазнини

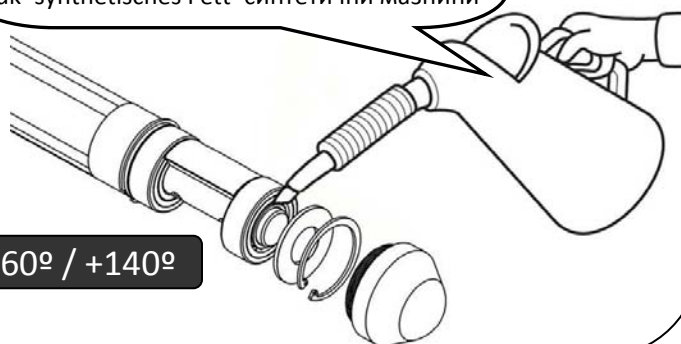

-60° / +140°

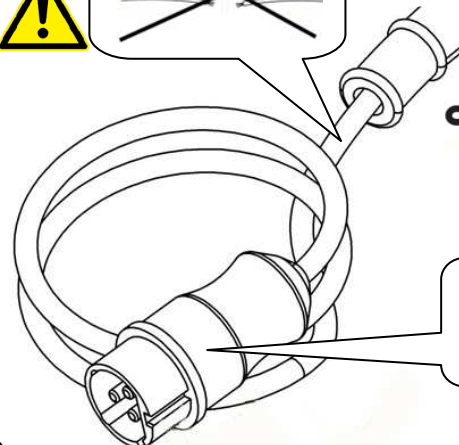
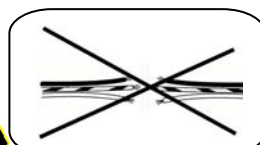

CHECK

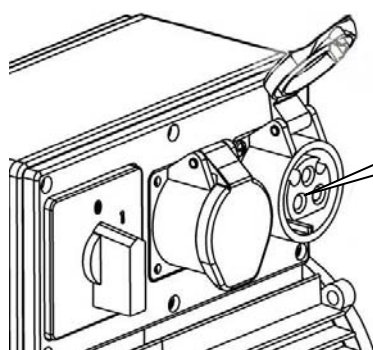

⚡ 3x42V
200Hz



CHECK

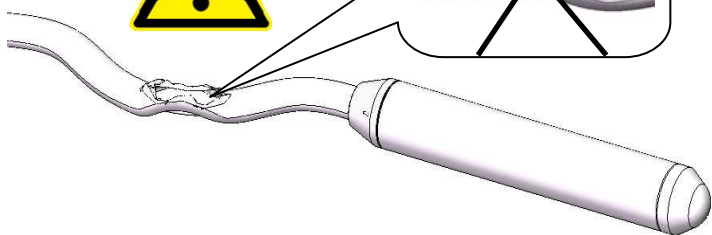
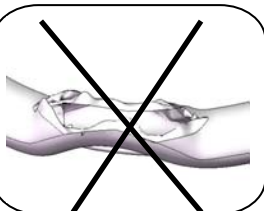
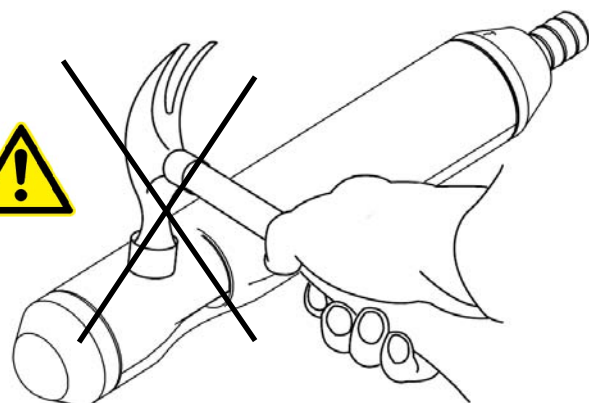

* OPERATIVA * OPERATION * FONCTIONNEMENT * DRIFT
* PRACA URZADZENIA * РАБОЧИЕ * NAUDOJIMAS * UTILIZAREA * BRUK
* POKYNY PRO PROVOZ * HANDHABUNG * ОПЕРАТИВНА *

