



IMPACT 430

Spare parts

Pièces de rechange

Reservdelar

Spare part's Manual



Manufacturer

Uni-corp Europe S.A.R.L. Paclite Equipment

33 Avenue Pierre Brossolette,
94048 Créteil Cedex,
FRANCE



+33 (0) 1 49 81 69 55



+33 (0) 1 48 98 40 88



sales@paclite-equip.com



paclite-equip.com



GEARBOX ASSEMBLY

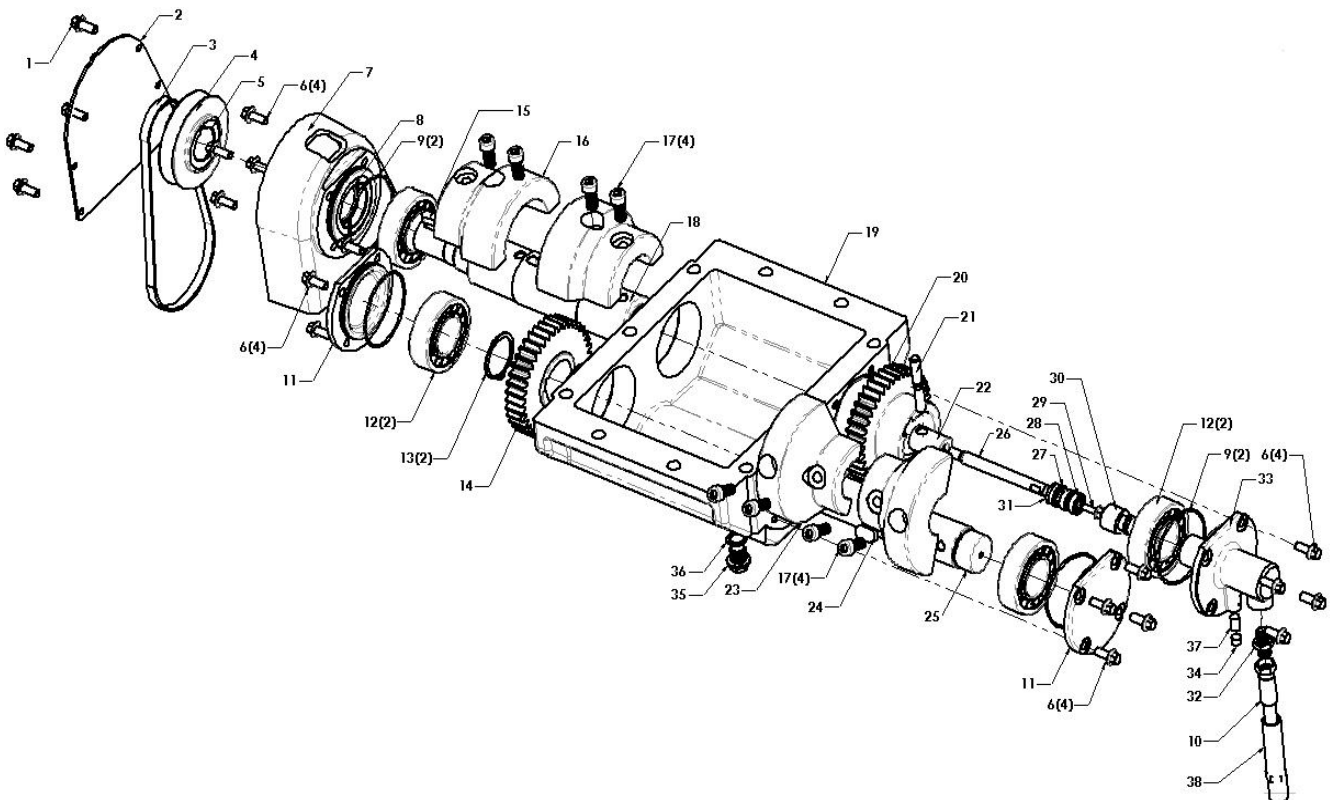

NO.	PART NAME	MATERIAL SPECIFICATION	QTY	REMARKS
01-1	Bolt	HF.B-M6X15-8.8-DIN-2	6	DIN 6921
01-2	V-belt Seal Sheet	Q235-A	1	
01-3	V-belt	Optivelt BX38	1	
01-4	Gear Box Pulley		1	DIN 2211
01-5	Taper Bore Bush		1	DIN 1610
01-6	Bolt	HF.B-M8X20-8.8-DIN-2	16	DIN 6921
01-7	V-belt Cover Base Plate		1	
01-8	Gear Box Oil seal	Ok NBR 47X42X7	1	
01-9	Oil ring	NBR 36624 76X2	4	
01-10	Hydraulic Hose	1200 mm with 22111-04-04 Connector	1	
01-11	Bearing Cover		2	
01-12	Roller bearing	NJ2208-E-M1A-C4	4	FAG
01-13	Circlip-Secondary Axle	CS.RG45	2	DIN471
01-14	Secondary gear	42CrMo	1	
01-15	Primary Axle key	10X7X32	1	
01-16	Eccentric weight-primary	S20C	2	
01-17	Socket Head Screw	HS.B-M10x25-12.9-GB-1	8	DIN 6912
01-18	Primary Axle	42GrMO	1	
01-19	GearBox	QT500	1	
01-20	Switch gear	42CrMo	1	
01-21	Led pin	GCr15	1	
01-22	Guide led Pin	45#	1	
01-23	Eccentric weight-Secondary	S20C	2	
01-24	Secondary Axle Key	Key.A-14X6X25	1	
01-25	Secondary axle	45#	1	
01-26	Plunger rod	S45C	1	
01-27	Circlip-Switch Plunger	CH.RG23	1	DIN472
01-28	Ball bearing	FAG608	2	
01-29	Bolt	HF.B-M6X20-8.8-DIN-2	1	DIN 6921
01-30	Switch Plunger	45#	1	
01-31	Oil Seal-Plunger	GROEF AUN100 PUR 16X26 L=8	1	
01-32	GB Connector	1B-04	1	
01-33	Switch Cylinder	GGG50	1	

01-34	Socket Screw	ConeHSS.S-M10X10-GB-3	1	DIN 914
01-35	Bolt	HHOS.B-M16x2	1	
01-36	Washer	ZH-D-M16	1	
01-37	Pluger R Seal	Rubber	1	
01-38	Spiral Guard	SGX -20 16mm - 26 mm and L = 1000 mm	1	

BASEPLATE ASSEMBLY

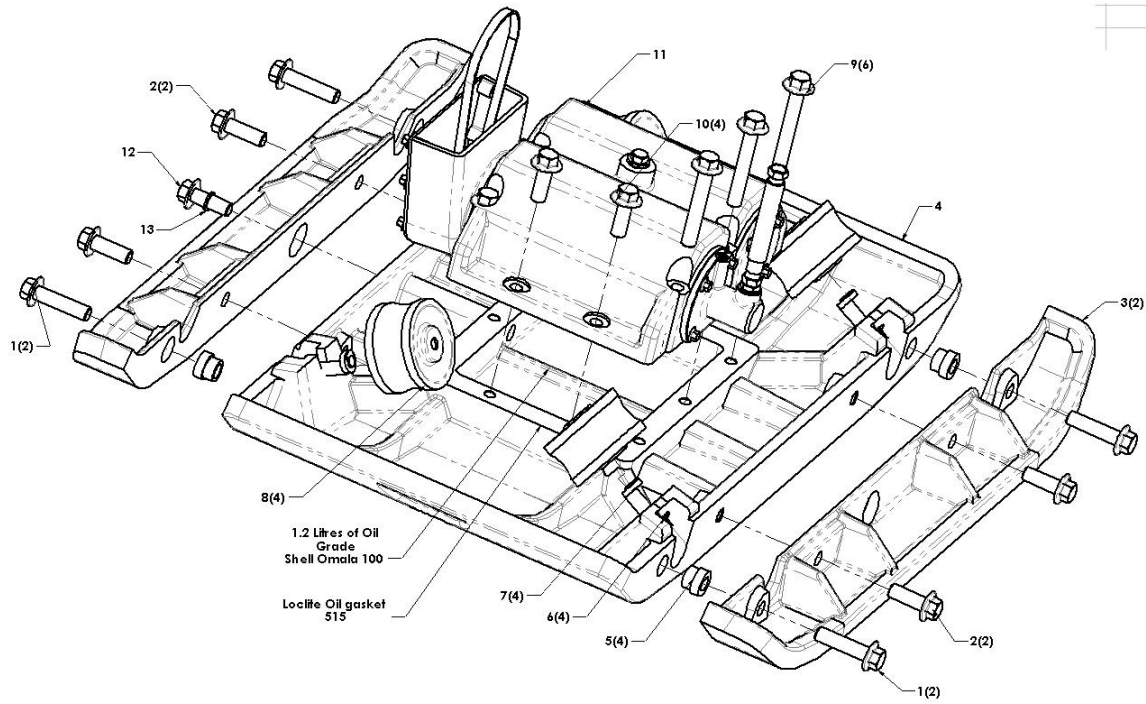

NO.	PART NAME	MATERIAL SPECIFICATION	QTY	REMARKS
02-1	Bolt	HF.B-M16X65-8.8-DIN-2	4	DIN 6921
02-2	Bolt	HF.B-M16X50-8.8-DIN-2	4	DIN 6921
02-3	BottomPlate Extension		2	
02-4	BottomPlate		1	
02-5	Base plate precision mount		4	
02-6	Bolt	HF.B-M12X30-12.9-DIN-2	4	DIN 6921
02-7	Base Plate Support		4	
02-8	Shock mount 100x62	Rubber 65 Shore	4	
02-9	Bolt	HF.B-M12X100-12.9-DIN-2	6	DIN 6921
02-10	Bolt	HF.B-M12X40-12.9-DIN-2	4	DIN 6921
02-11	GearBox Assembly		1	
02-12	Bolt	HHOS.B-M-M16X2X25	1	
02-13	Washer	ZH-D-M16	1	

COVERREAR ASSEMBLY

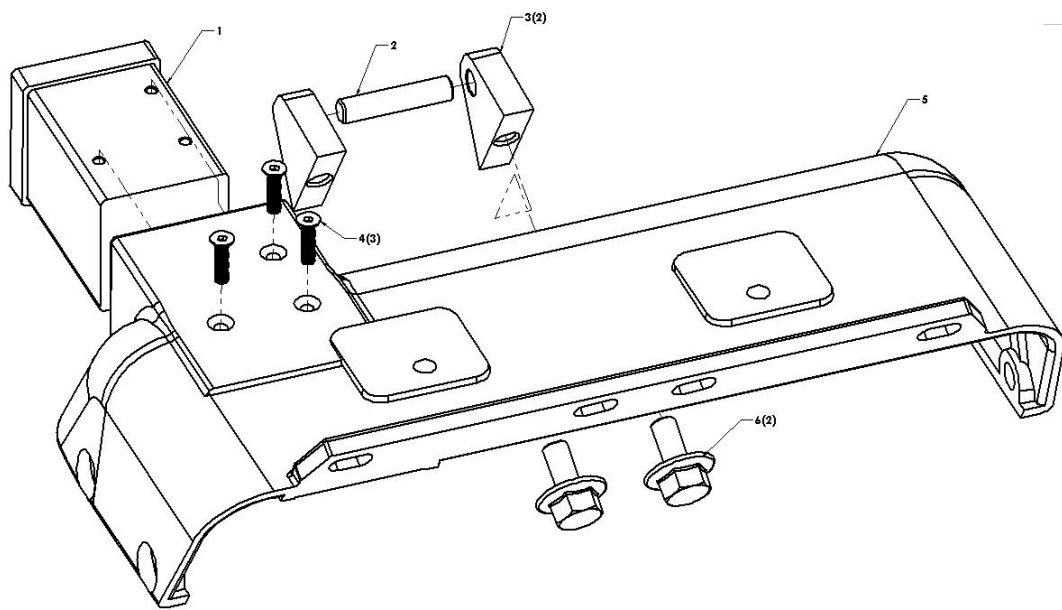

NO.	PART NAME	MATERIAL SPECIFICATION	QTY	REMARKS
03-1	Key Switch	HATZ 1B40U-3	1	
03-2	Support Pin	SUS304	1	
03-3	Support		2	
03-4	Set Screw	HSF.S-M6x30-8.8-DIN-1	3	DIN 7991
03-5	Cover Rear		1	
03-6	Bolt	HF.B-M10X25-8.8-DIN-2	4	DIN 6921

BATTERY ASSEMBLY

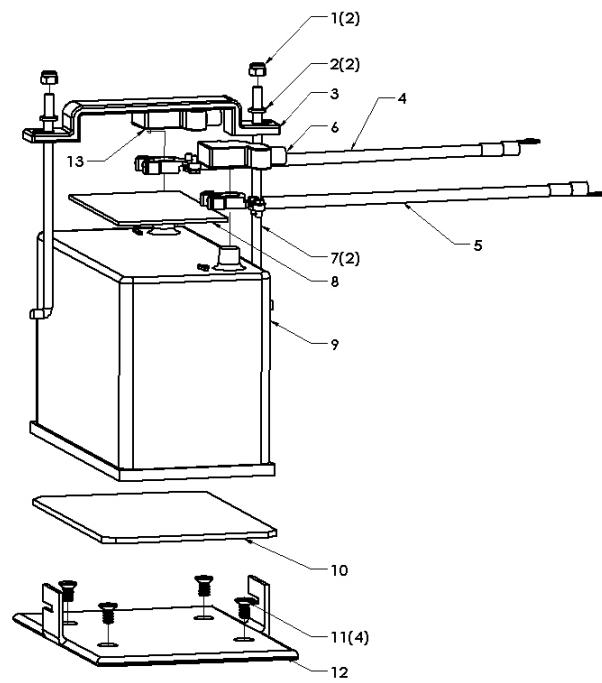

NO.	PART NAME	MATERIAL SPECIFICATION	QTY	REMARKS
04-1	Lock Nut	IN.N-M8-DIN-1	2	DIN982
04-2	Washer	FN.W8-DIN-1	2	DIN125-A
04-3	Battery Support 2		1	
04-4	Cathode Wire		1	IEC53(RVV)
04-5	Anode wire		1	IEC53(RVV)
04-6	Anode Cap		1	
04-7	Battery Support Rod		2	
04-8	Battery Retainer	Rubber	1	
04-9	Battery	Sail 6-QW-60	1	DIN 55559
04-10	Battery Bottom Cover	Rubber	1	
04-11	Set Screw	HSF.S-M8x16-8.8-DIN-1	4	DIN 7991
04-12	Battery Bottom Plate		1	
04-13	Cathode Cap		1	

SAFETY COVER ASSEMBLY

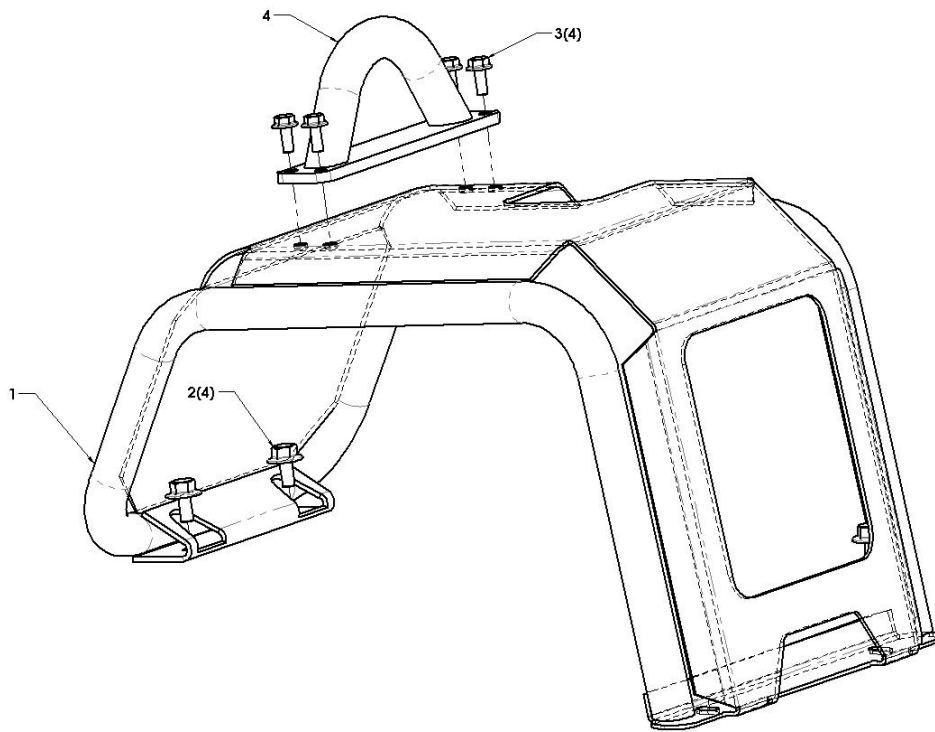

NO.	PART NAME	MATERIAL SPECIFICATION	QTY	REMARKS
05-1	Safety Cover Weldment		1	
05-2	Bolt	HF.B-M12X25-8.8-DIN-2	4	DIN 6921
05-3	Bolt	HF.B-M10X25-8.8-DIN-2	4	DIN 6921
05-4	Lift eye		1	

ENGINEBASE ASSEMBLY

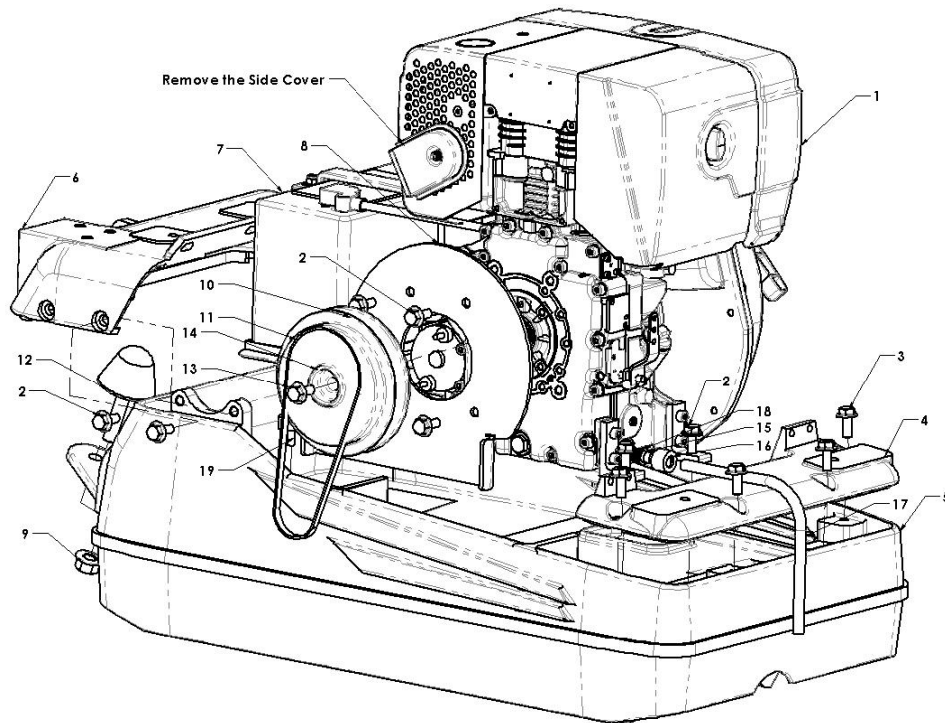

NO.	PART NAME	MATERIAL SPECIFICATION	QTY	REMARKS
05-1	Hatz Engine	1B40U-3	1	
05-2	Bolt	HF.B-M10X25-8.8-DIN-2	13	DIN 6921
05-3	Bolt	HF.B-M10X40-8.8-DIN-2	4	DIN 6921
05-4	Cover Front		1	
05-5	Engine Base		1	
05-6	CoverRear Assembly		1	
05-7	Battery Assembly		1	
05-8	Cover V-Belt Plate		1	
05-9	Nut	HF.N-M16-DIN-3	1	
05-10	Centrifugal clutch	Amsbeck 125-1805	1	
05-11	V-belt	Optivelt BX38	1	
05-12	HandleBar Touch	RUBBER	1	
05-13	Bolt	FN.B-M10x1.25x40-8.8-DIN-1	1	
05-14	Washer	FN.W10-DIN-1	1	
05-15	Drain Knob	Brass	1	
05-16	Drain Connector	Brass	1	
05-17	Hose	Ø13×2.5,L=300	1	
05-18	Hose Brand	Φ13	2	
05-19	Battery shock mount	Rubber	4	

HANDLEBAR ASSEMBLY

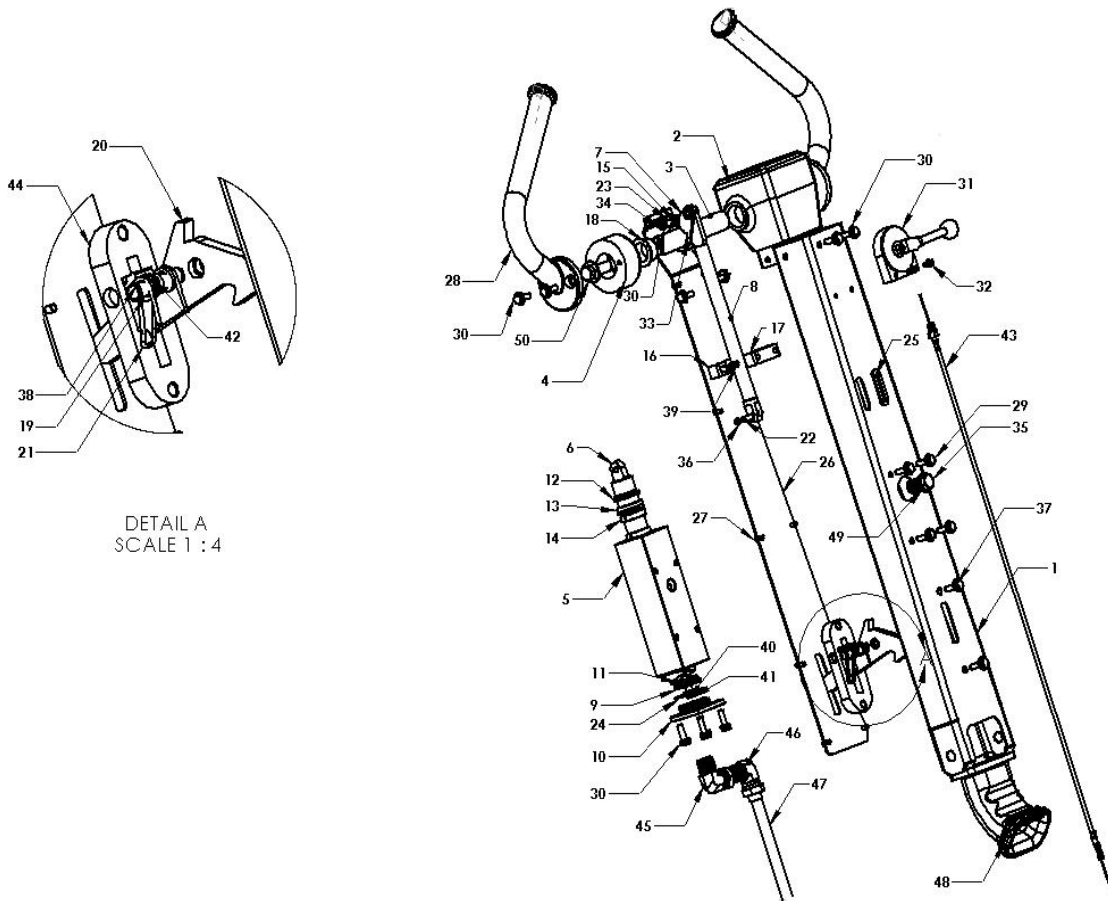

NO.	PART NAME	MATERIAL SPECIFICATION	QTY	REMARKS
05-1	Handle Support Welding		1	
05-2	Handle Bar Housing		1	
05-3	Handle Bar Axis		1	
05-4	Shift handle Bar Shock Mount	RUBBER	2	
05-5	Cylinder		1	
05-6	Piston	SU304	1	
05-7	Handle Lever		1	
05-8	Shift Bar Weldment		1	
05-9	Spring Holding Plate		1	
05-10	Cylinder Cover		1	
05-11	Cylinder Spring	5/SWPB	1	
05-12	Dust cover	24224428-NOK	1	
05-13	Oil seal	24187198-NOK	1	
05-14	Guide ring	GZ1293V0-NOK(RYT)	2	
05-15	Brass Bush	Brass	2	
05-16	Bracket 1		1	
05-17	Bracket 2		1	
05-18	Brass Bush	BRASS	2	
05-19	Hook Pin		1	
05-20	Hook		1	
05-21	Hair Spring	CrV	1	
05-22	Eye pin-pin 8x26	S45C	1	
05-23	Handle lever pin(pin 10x28)	S45C	1	
05-24	O-ring	48X2	1	
05-25	Cable slot rubber	RUBBER	1	
05-26	Handle bar		1	
05-27	Bolt	HF.B-M6x10-8.8-DIN-1	13	DIN 6921
05-28	Shift handle bar assembly		2	
05-29	Bolt	HF.B-M8x25-8.8-DIN-1	4	DIN 6921
05-30	Bolt	HF.B-M8x20-8.8-DIN-1	10	DIN 6921
05-31	Control lever		1	
05-32	Bolt	HF.B-M6x20-8.8-DIN-1	2	DIN 6921

05-33	key	CPT400-A-8x7x32	1	
05-34	Circlip	CS.RG10	2	DIN 472
05-35	Bolt	HHOS.B-M20x1.5	1	
05-36	Circlip	CS.RG8	2	DIN 472
05-37	Bolt	HF.B-M10x25-8.8-DIN-2	2	DIN 6921
05-38	Circlip	CS.RG12	4	DIN 472
05-39	Bolt	HS.B-M8x50-8.8-GB-1	2	
05-40	Washer	FN.W10-DIN-1	1	
05-41	Bolt	FN.B-M10x25-8.8-DIN-1	1	
05-42	Hook Pin Nylon Bracket	Nylon	2	
05-43	Control Cable		1	
05-44	Hook Frame		1	
05-45	Connector		1	1BG9-04OG
05-46	Connector-2		1	2B9-04
05-47	Hydraulic Hose		1	
05-48	HandleBar Tube	Rubber	1	
05-49	Washer	ZH-D-M20	1	
05-50	Bolt	HF.B-M12x30-8.8-DIN-2	2	

IMPACT 430 ASSEMBLY

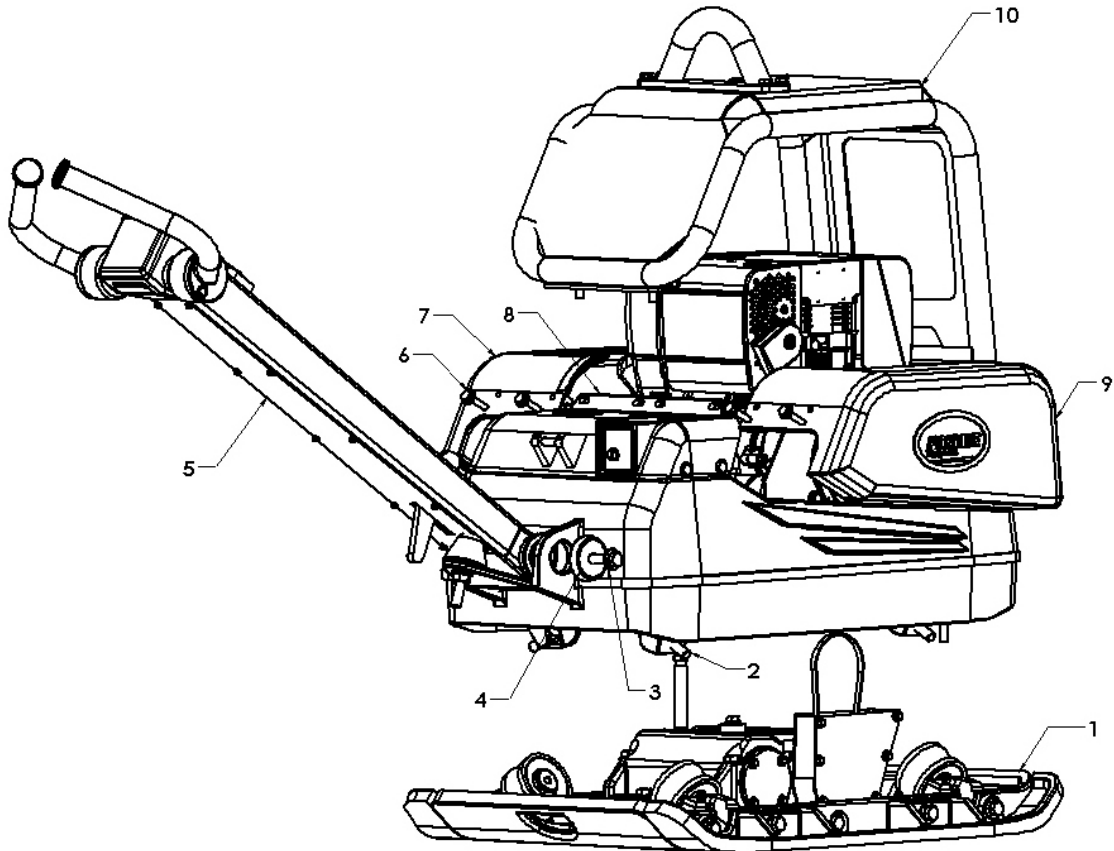

NO.	PART NAME	MATERIAL SPECIFICATION	QTY	REMARKS
00-1	Base Plate Assembly		1	
00-2	Bolt	HS.B-M12X40-12.9-GB-1	4	DIN 6921
00-3	Bolt	HS.B-M16X70-8.8-GB-1	4	DIN 6921
00-4	Handle Bar Shock Mount	Rubber	4	
00-5	Handle Bar Assembly		1	
00-6	Bolt	HS.B-M10X40-8.8-GB-1	8	DIN 6921
00-7	Cover Left		1	
00-8	Rubber Patch	Rubber	1	
00-9	Cover V-Belt		1	
00-10	Safety Cover Assembly		1	

