

# M900S-01 SPIDER ASSY

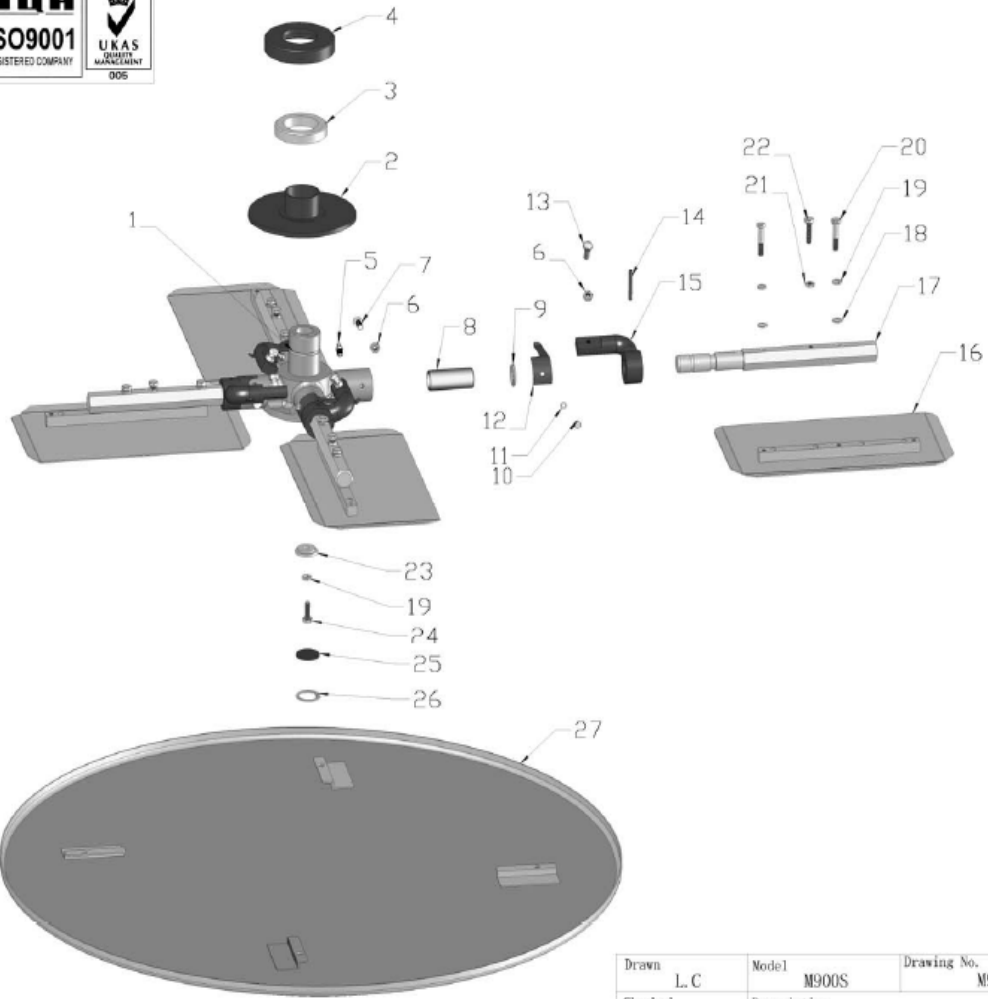

Drawn	L. C	Model	M900S	Drawing No.	M900S-01
Checked		Description	SPIDER ASSY.		
Approved		Date	2009. 10. 27		

## M900S-01 SPIDER ASSY

NO. 序号	PART NO. 图号	PART DESCRIPTION 品名	QTY 数量	UNIT PRICE (EUR)
01-1	M900S-947-00609	SPIDER (十字连接器)	1	
01-2	M900S-947-00603	TILT PLATE (台阶圈)	1	
01-3	M900S-W01-NIS-55TNK29	BEARING (轴承)	1	
01-4	M900S-947-00605	BEARING HOUSING (轴承盖)	1	
01-5	M900S-TOL-T-001	GREASE NIPPLE (黄油嘴)	4	
01-6	M900S-FN.N-M8-DIN-1	NUT (螺母)	8	
01-7	M900S-FN.B-M8x20-8.8-DIN-1	BOLT (六角螺栓)	4	
01-8	M900S-50-000067	SPIIDER BUSH (铜套)	4	
01-9	M900S-W04-25x2	O RING (O型圈)	4	
01-10	M900S-FN.B-M6x10-8.8-DIN-1	BOLT (六角螺栓)	4	
01-11	M900S-SPG.W6-DIN-1	SPRING WASHER (弹垫)	4	
01-12	M900S-947-00604	SPRING SLICE (刮片)	4	
01-13	M900S-SHH.B-M8x25	BOLT (球头螺栓)	4	
01-14	M900S-SC.PIN-5x40	SPRING PIN (弹性圆柱销)	4	
01-15	M900S-947-00602	TILT ARM (连接头)	4	
01-16	M900S-111.8.002	COMBINATION BLADE(刀片)	4	
01-17	M900S-947-00601	SPIDER ARM (六角棒)	4	
01-18	M900S-FN.W8-DIN-1	WASHER (平垫)	8	
01-19	M900S-HSPG.W8-DIN-1	SPRING WASHER, TANG ENDS(重型弹垫)	9	
01-20	M900S-FN.B-M8x45-8.8-DIN-1	BOLT (六角螺栓)	8	
01-21	M900S-FNL.N-M8	HEXAGON THIN NUT(六角薄螺母)	4	
01-22	M900S-FN.B-M8x35-8.8-DIN-1	BOLT (六角螺栓)	4	
01-23	M900S-947-99945	WASHER (垫圈)	1	
01-24	M900S-FN.B-M8x25-8.8-DIN-1	BOLT (六角螺栓)	1	
01-25	M900S-100G-040305	RUBBER WASHER (橡胶垫)	1	
01-26	M900S-CH.RG36	INTERNAL CIRCLIP (孔用挡圈)	1	
01-27	M900S-100GB-080000P	ROUND PAN(抹盘)	1	

# M900S-02 GEARBOX ASSY

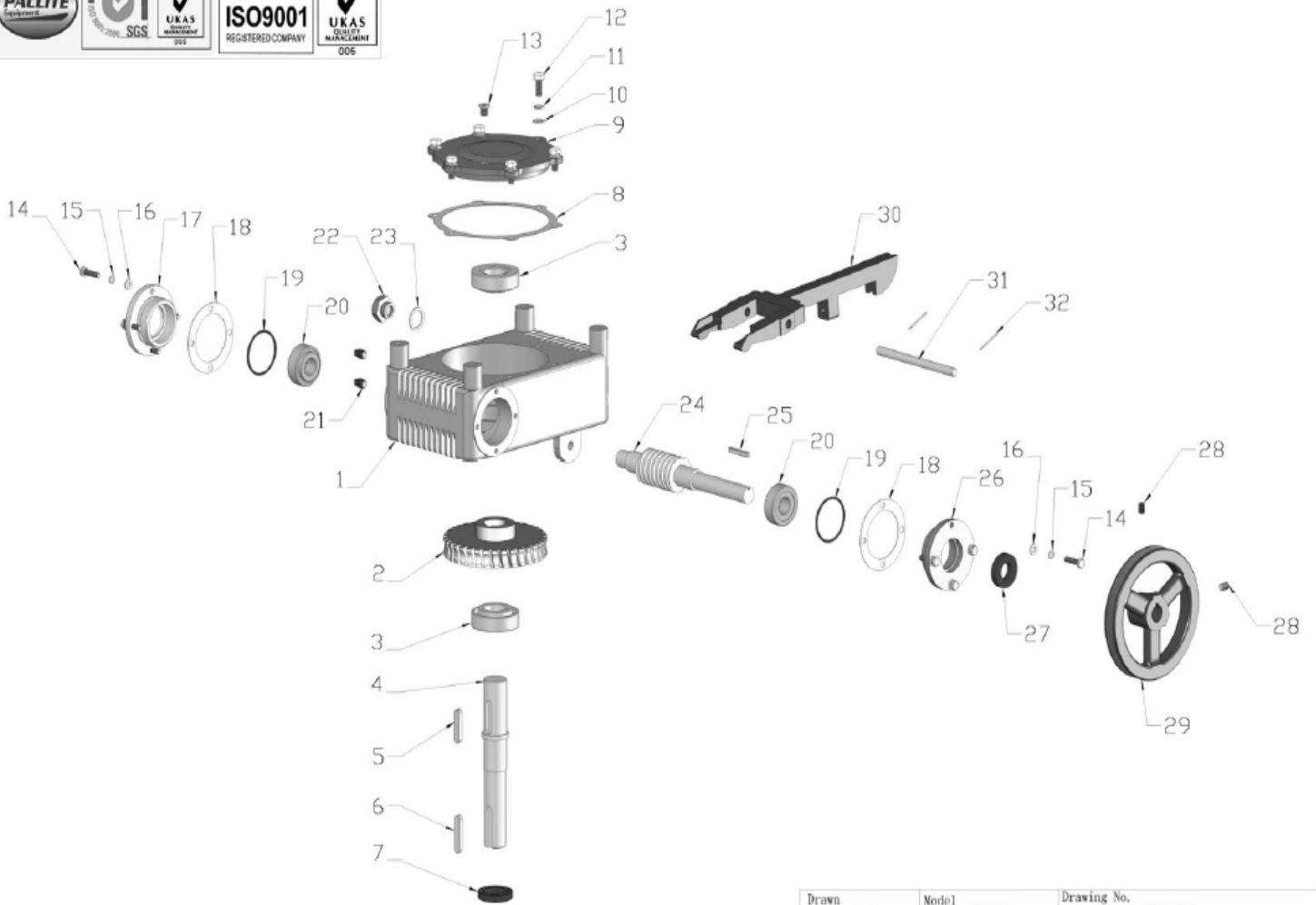

Drawn	L. C	Model	M900S	Drawing No.	M900S-02
Checked		Description	GEARBOX ASSY		
Approved		Date	2009. 10. 27		

# M900S-02 GEARBOX ASSY

NO. 序号	PART NO. 图号	PART DESCRIPTION 品名	QTY 数量	UNIT PRICE (EUR)
02-1	M900S-947-040001	WORM GEAR BOX (蜗轮箱)	1	
02-2	M900S-100GB-040107	WORM GEAR (蜗轮)	1	
02-3	M900S-W01-32206-J	BEARING (轴承)	2	
02-4	M900S-100GB-040115	WORM GEAR SHAFT (蜗轮轴)	1	
02-5	M900S-Key.A-8x7x40	KEY (平键)	1	
02-6	M900S-Key.A-8x7x45	KEY (平键)	1	
02-7	M900S-W03-45x30x8	OIL SEAL (油封)	1	
02-8	M900S-100GB-040402	SEAL, TOP COVER(蜗轮箱盖纸垫)	1	
02-9	M900S-100GB-040110	TOP COVER (蜗轮箱盖)	1	
02-10	M900S-FN.W8-DIN-1	WASHER (平垫)	6	
02-11	M900S-SPG.W8-DIN-1	SPRING WASHER (弹垫)	6	
02-12	M900S-FN.B-M8x20-8.8-DIN-1	BOLT (六角螺栓)	6	
02-13	M900S-100G-000004	VENT SCREW (螺纹通气螺丝)	1	
02-14	M900S-FN.B-M6x25-8.8-DIN-1	BOLT (六角螺栓)	8	
02-15	M900S-SPG.W6-DIN-1	SPRING WASHER (弹垫)	8	
02-16	M900S-FN.W6-DIN-1	WASHER (平垫)	8	
02-17	M900S-100GB-040302	CLOSE COVER (闷盖)	1	
02-18	M900S-100GB-040401	SEAL, SIDE COVER(侧盖密封垫)	2	
02-19	M900S-W04-47.7x2.65	O RING (O型圈)	2	
02-20	M900S-W01-32204-J	BEARING (轴承)	2	
02-21	M900S-100GB-040111	STOPPER (堵头)	2	
02-22	M900S-100GB-041000	OIL GAUGE (油标)	1	
02-23	M900S-ZH-D-M20	WASHER (组合垫圈)	1	
02-24	M900S-120GB-040308	WORM (蜗杆)	1	
02-25	M900S-Key.A-5x5x32	KEY (平键)	1	
02-26	M900S-100GB-040310	SIDE COVER (透盖)	1	
02-27	M900S-W03-40x20x8	OIL SEAL (油封)	1	
02-28	M900S-FHSS.S-M8x12	GRUB SCREW (内六角平端紧定螺钉)	2	
02-29	M900S-947-99988	GEARBOX PULLEY(皮带轮)	1	
02-30	M900S-100G-060400	TILT YOKE (拨叉)	1	
02-31	M900S-100G-060500	SHAFT (轴)	1	
02-32	M900S-SP.PIN-2x26	SPLIT PIN (开口销)	2	

# M900S-03 ENGINE BASE AND CLUTCH ASSY

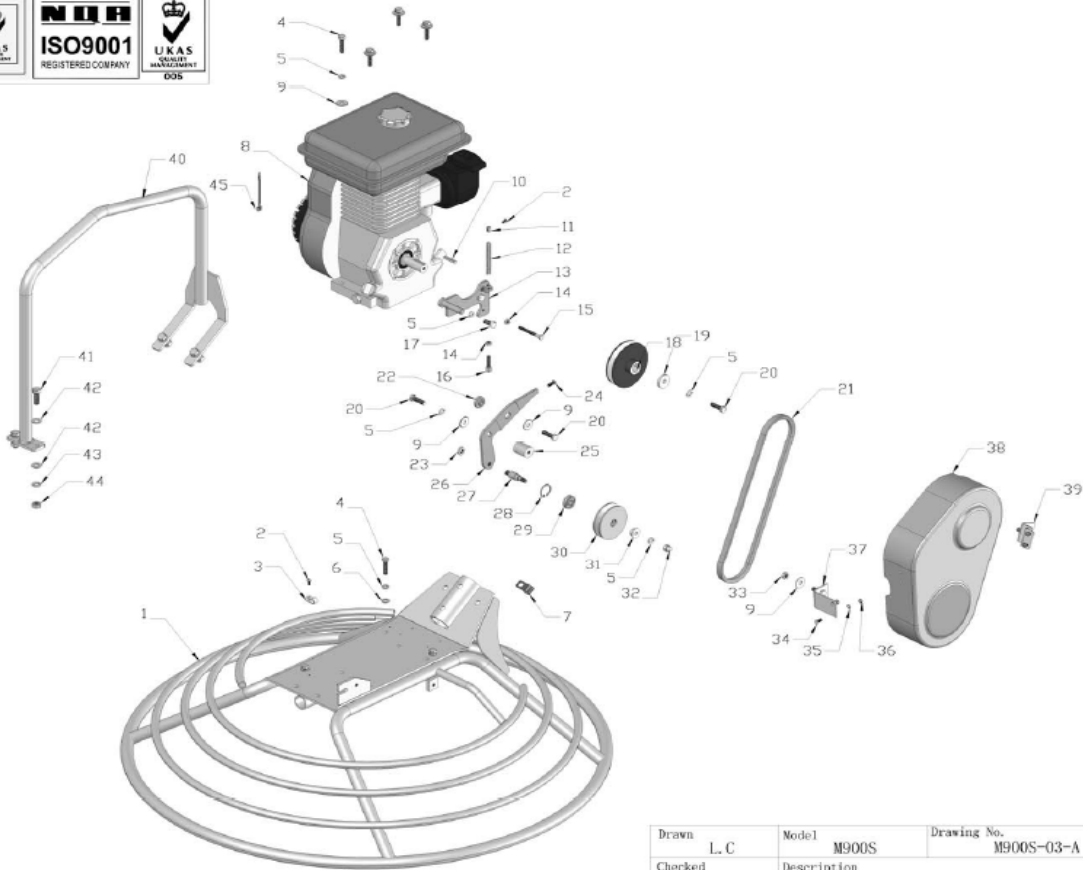

Drawn	L. C	Model	M900S	Drawing No.	M900S-03-A
Checked		Description	ENGINE BASE AND MANUAL CLUTCH ASSY		
Approved		Date	2009.10.27		

# M900S-03 ENGINE BASE AND CLUTCH ASSY

NO. 序号	PART NO. 图号	PART DESCRIPTION 品名	QTY 数量	UNIT PRICE (EUR)
03-1	M900S-90GB-020000	GUARD RING(防护圈)	1	
03-2	M900S-PAN.S-M4x10-GB-2	PAN HEAD SCREW (十字盘头槽螺钉)	2	
03-3	M900S-X1-J-10.4	CABLE CLAMP(固线夹)	1	
03-4	M900S-FN.B-M8x35-8.8-DIN-1	BOLT (六角螺栓)	8	
03-5	M900S-HSPG.W8-DIN-1	SPRING WASHER, TANG ENDS (重型弹垫)	15	
03-6	M900S-FN.W8-DIN-1	WASHER (平垫)	4	
03-7	M900S-90GB-030900F	CLIP (R形夹)	1	
03-8	M900S-W05-EY20	ENGINE (引擎)	1	
03-9	M900S-WOD.W8-GB-1	WASHER (大垫圈)	8	
03-10	M900S-Key.B-5x5x30	KEY (平键)	1	
03-11	M900S-947-99965	CABLE RETAINER (绳夹)	1	
03-12	M900S-2-0060	MANUAL CLUTCH SPRING(弹簧)	1	
03-13	M900S-947-01600	MOUNTING PLATE(支撑板)	1	
03-14	M900S-FN.N-M6-DIN-1	NUT (螺母)	2	
03-15	M900S-FN.B-M6x60-8.8HALF-DIN-1	BOLT (六角螺栓)	1	
03-16	M900S-947-99971	CABLE ADJUSTER(调节螺栓)	1	
03-17	M900S-FN.B-M8x20-8.8-DIN-1	BOLT (六角螺栓)	3	
03-18	M900S-90GB-030700F	PTO PULLEY(输出轴皮带轮)	1	
03-19	M900S-80-0319	WASHER (垫圈)	1	
03-20	M900S-FN.B-M8x30-8.8-DIN-1	BOLT (六角螺栓)	3	
03-21	M900S-W02-A31-OPT	V-BELT (V型皮带)	1	
03-22	M900S-90GB-030800F	TENSIONING LEVER BUSH(衬套)	1	
03-23	M900S-FNL.N-M10-DIN-1	HEXAGON THIN NUT (六角薄螺母)	1	
03-24	M900S-PAN.S-M5x16	PAN HEAD SCREW (十字盘头槽螺钉)	1	
03-25	M900S-947-99913	THREADED BOSS (螺纹套)	1	
03-26	M900S-947-99912	CLUTCH ARM(张紧臂)	1	
03-27	M900S-947-99920	MANUAL CLUTCH BOLT(螺栓)	1	
03-28	M900S-CH.RG28	INTERNAL CIRCLIP(孔用弹性挡圈)	1	
03-29	M900S-W01-6001ZZ-J	BEARING (轴承)	1	
03-30	M900S-947-99918	TENSIONING PULLEY(张紧轮)	1	
03-31	M900S-947-99970	SPACER TOP HAT(端盖)	1	
03-32	M900S-HC.N-M8-DIN-2	CAP NUT (盖型螺母)	1	
03-33	M900S-FN.N-M8-DIN-1	NUT (螺母)	1	
03-34	M900S-FN.B-M5x12-8.8	BOLT (六角螺栓)	4	
03-35	M900S-FN.W5-DIN-1	WASHER (平垫)	4	
03-36	M900S-947-000017	LOCK NUT(锁紧螺母)	4	
03-37	M900S-947-08300	BELT GUARD BRACKET(皮带罩耳座)	1	
03-38	M900S-90GB-031000F	BELT GUARD (皮带罩)	1	
03-39	M900S-120GB-030700F	GUARD BRACKET(皮带罩耳座)	1	
03-40	M900S-90GB-030200R	LIFTING HANDLE(起吊管)	1	
03-41	M900S-FN.B-M10x30-8.8-DIN-1	BOLT (六角螺栓)	4	
03-42	M900S-FN.W10-DIN-1	WASHER (平垫)	8	
03-43	M900S-HSPG.W10-DIN-1	SPRING WASHER, TANG ENDS (重型弹垫)	4	
03-44	M900S-FN.N-M10-DIN-1	NUT (螺母)	4	
03-45	M900S-90GB-000015	WIRE (电线)	1	

# M900S-04 OPERATION HANDLE ASSY

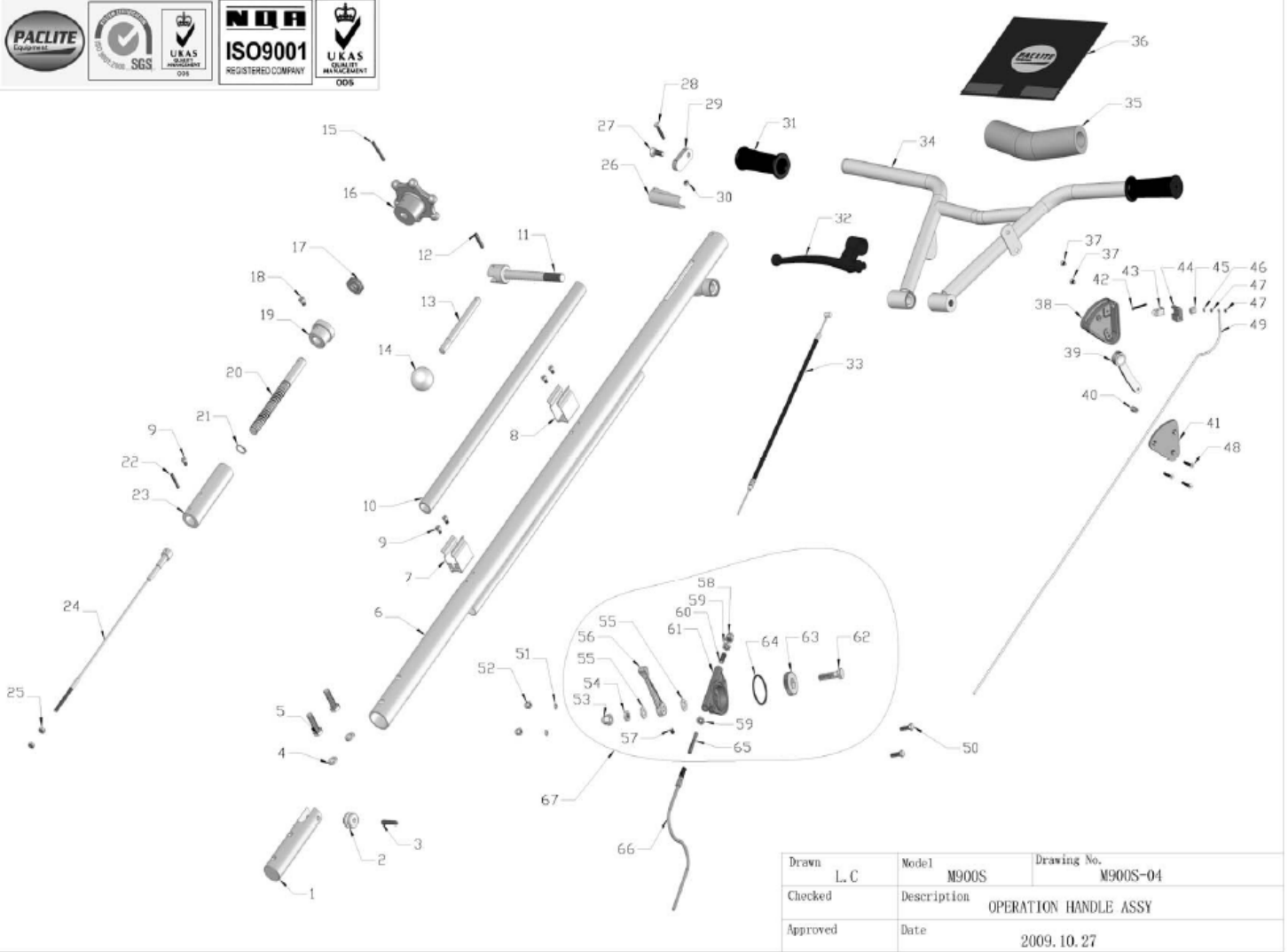

Drawn	L. C	Model	M900S	Drawing No.	M900S-04
Checked		Description	OPERATION HANDLE ASSY		
Approved		Date	2009. 10. 27		

# M900S-04 OPERATION HANDLE ASSY

NO. 序号	PART NO. 图号	PART DESCRIPTION 品名	QTY 数量	UNIT PRICE (EUR)
04-1	M900S-100G-010005	WHEEL BLOCK (滚轮支架)	1	
04-2	M900S-100G-010004	WHEEL (滚轮)	1	
04-3	M900S-SC.PIN-8x32	SPRING PIN (弹性圆柱销)	1	
04-4	M900S-HSPG.W10-DIN-1	SPRING WASHER, TANG ENDS (重型弹垫)	2	
04-5	M900S-FN.B-M10x35-8.8-DIN-1	BOLT (六角螺栓)	2	
04-6	M900S-120GB-090100P	HANDLE BOTTOM (下扶手)	1	
04-7	M900S-100GBII-000003	SPRING CLIP 2(抬棒抱箍2)	1	
04-8	M900S-100GBII-000001	SPRING CLIP 1(抬棒抱箍1)	1	
04-9	M900S-HS.B-M5x8-8.8-GB-1	SCREW (内六角螺钉)	5	
04-10	M900S-100GBII-000002	LIFTING TUBE(抬棒)	1	
04-11	M900S-947-06606	SCREWD-TOMMY BAR (锁紧螺杆)	1	
04-12	M900S-SC.PIN-6x30	SPRING PIN (弹性圆柱销)	1	
04-13	M900S-947-99947	BAR (杆)	1	
04-14	M900S-SH.A-M12x40	GRIP BALL (手柄球)	1	
04-15	M900S-SC.PIN-5x40	SPRING PIN (弹性圆柱销)	1	
04-16	M900S-100G-010008P	PITCH CONTROL KNOB(钢丝绳调节把手)	1	
04-17	M900S-W01-51103-J	BEARING (轴承)	1	
04-18	M900S-HS.B-M6x8-8.8-GB-1	SCREW (内六角螺钉)	1	
04-19	M900S-100G-010006	BEARING COVER (调节盖)	1	
04-20	M900S-100G-010003	ADJUSTING SCREW (调节螺杆)	1	
04-21	M900S-CS.RG16	EXTERNAL CIRCLIP (轴用挡圈)	1	
04-22	M900S-SC.PIN-5x30	SPRING PIN (弹性圆柱销)	1	
04-23	M900S-100G-010002	SLIDE BUSH (调节活塞)	1	
04-24	M900S-120GB-000010	DEPTH CONTROL CABLE ASSY (刮板调节钢丝总成)	1	
04-25	M900S-FN.N-M6-DIN-1	NUT (螺母)	2	
04-26	M900S-947-01802	PRESSING CLUTCH AID(助力器)	1	
04-27	M900S-HSF.S-M8x25	SOCKET COUNTERSUNK HEAD SCREW (内六角沉头螺钉)	1	
04-28	M900S-FN.B-M5x30-8.8-DIN-1	BOLT (六角螺栓)	1	
04-29	M900S-947-01801	CLUTCH LEVER CONNECTOR(连接块)	1	
04-30	M900S-FN.N-M5-DIN-1	NUT (螺母)	1	
04-31	M900S-100G-010001	HANDLE COVER (扶手套)	2	
04-32	M900S-947-99996	CONTROL LEVER (操纵把手)	1	
04-33	M900S-90GB-090000F	CLUTCH CABLE(张紧线)	1	
04-34	M900S-120GB-090200F	HANDLEBAR(上扶手)	1	
04-35	M900S-947-99998	HANDLE FOAM(海绵护套)	1	
04-36	M900S-120GB-000005	HANDLE FABRIC(扶手布)	1	
04-37	M900S-F.S-M5x10	COUNTERSUNK HEAD SCREW (螺钉)	2	
04-38	M900S-100G-010101	CUTOUT SWITCH SHELL (安全开关壳)	1	
04-39	M900S-100G-010103	CUTOUT SWITCH LEVER (安全开关扳杆)	1	
04-40	M900S-100G-010104	CUTOUT SWITCH BUSH (安全开关套)	1	
04-41	M900S-100G-010102	CUTOUT COVER (安全开关盖)	1	
04-42	M900S-F.S-M3x30	COUNTERSUNK HEAD SCREW(十字槽沉头螺钉)	1	
04-43	M900S-100G-010107	CUTOUT SWITCH REED (安全开关弹簧片)	1	
04-44	M900S-100G-010105	CUTOUT SWITCH OUTLET (安全开关座)	1	
04-45	M900S-100G-010106	CUTOUT SWITCH WASHER (安全开关垫圈)	1	

# M900S-04 OPERATION HANDLE ASSY

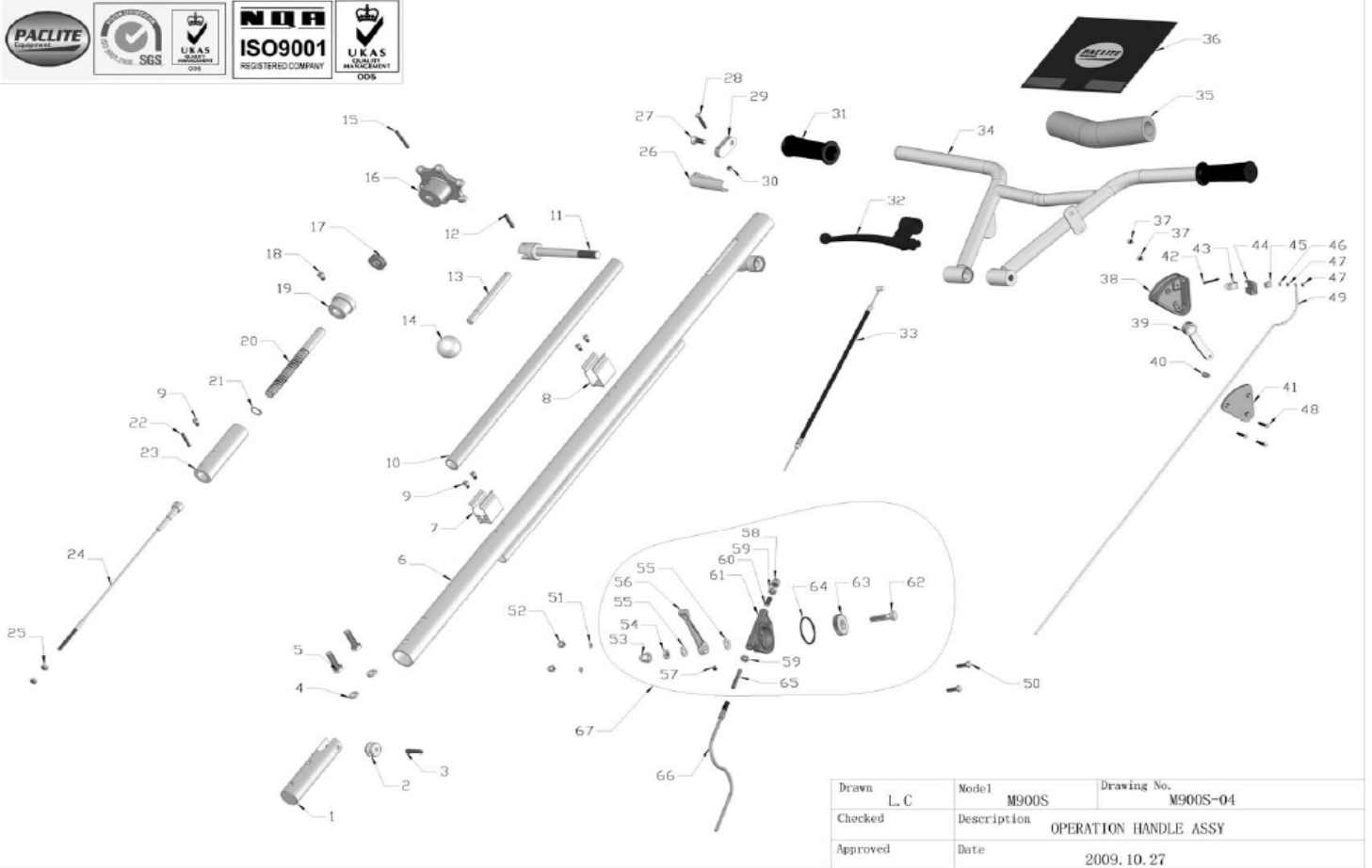

NO. 序号	PART NO. 图号	PART DESCRIPTION 品名	QTY 数量	UNIT PRICE (EUR)
04-46	M900S-FN.W3-DIN-2	WASHER (平垫)	1	
04-47	M900S-FN.N-M3-DIN-1	NUT (螺母)	2	
04-48	M900S-F.S-M4x25	COUNTERSUNK HEAD SCREW (十字沉头螺钉)	3	
04-49	M900S-100G-000014	WIRE HARNESS (电线)	1	
04-50	M900S-FN.B-M6x20-8.8-DIN-2	BOLT (六角螺栓)	2	
04-51	M900S-SPG.W6-DIN-2	SPRING WASHER (弹垫)	2	
04-52	M900S-HC.N-M6-DIN-2	CAP NUT (盖型螺母)	2	
04-53	M900S-HC.N-M10-DIN-2	CAP NUT (盖形螺母)	1	
04-54	M900S-FNL.N-M10-DIN-2	HEXAGON THIN NUT (六角薄螺母)	1	
04-55	M900S-FN.W10-DIN-2	WASHER (平垫)	2	
04-56	M900S-70ND-060000	THROTTLE LEVER (油门开关把手)	1	
04-57	M900S-FHSS.S-M6x8-GB-3	SOCKET SCREW WITH FLAT HEAD (内六角平端紧定螺钉)	1	
04-58	M900S-HC.N-M8-DIN-2	CAP NUT (盖型螺母)	1	
04-59	M900S-FNL.N-M8-DIN-2	HEXAGON THIN NUT (六角薄螺母)	2	
04-60	M900S-FHSS.S-M8x20-GB-3	SOCKET SCREW WITH FLAT HEAD (内六角平端紧定螺钉)	1	
04-61	M900S-70ND-060001	THROTTLE BODY (油门把手盖)	1	
04-62	M900S-70ND-060003	BOLT (油门螺栓)	1	
04-63	M900S-70ND-060002	THROTTLE GEAR (齿轮)	1	
04-64	M900S-W04-45x3	O-RING (O形圈)	1	
04-65	M900S-70ND-060004	SLIDER (齿条)	1	
04-66	M900S-W06-S04-L1420x1620	THROTTLE CABLE (油门线)	1	
04-67	M900S-70ND-010018	THROTTLE LEVER ASSY(油门开关组件)	1	